

BORNE BÉTON GRANDE

Le Corbusier

Concrete outdoor and indoor floor and table lamp, conceived for the Unité d'habitation de Marseille and for Bhakra Dam, Sukhna Dam in India in 1952. Each lamp is a handcrafted product: small aesthetic and finishing differences between one lamp and the other make them unique.



LED INDOOR

LAMPING

Source	LED board
Total power	38,4W
Emission	direct
Switching	dimmable, according to bulb
Tension	110/230V
Color temperature	3000K
Luminous flux	3840lm
Typ cri	80
Energy class	A+
Materials	concrete + PMMA
Notes	cable lenght 2,7m, dimmer on cable
Net lamp weight	53 Kg

Codes

BBG LDW 22

Structure

concrete

PACKAGE

Package 01 60x45x60 cm / Gross weight: 61 Kg

Certificazioni

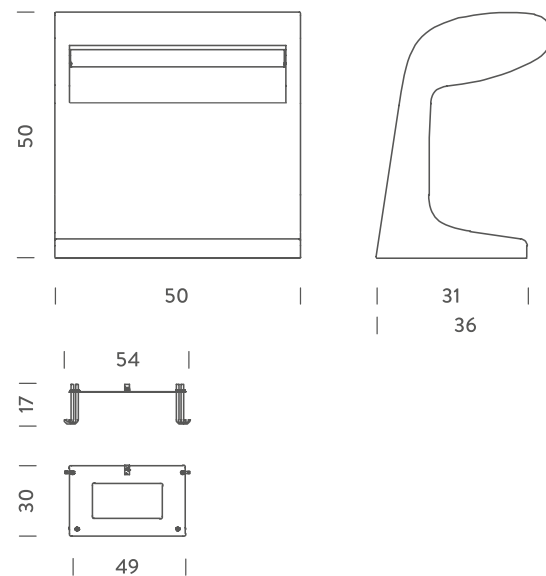

LED OUTDOOR IP44

LAMPING

Source	LED board
Total power	38,4W
Emission	direct
Tension	110/230V
Color temperature	3000K
Luminous flux	3840lm
Typ cri	80
Energy class	A+
Ip class	44
Materials	concrete + PMMA
Notes	cable lenght 3m, body and cable IP65 rated
Accessories	vandal proof fixing plate for outdoor version, zinced steel
Net lamp weight	53 Kg

Codes

BBG LDW 21

Structure

concrete

PACKAGE

Package 01 60x45x60 cm / Gross weight: 61 Kg

Certificazioni

